

Dimensions of machine

width 4620 mm
height 4512 mm
depth 3375 mm

**Dimensions of machine
+ filtration**

width 8085 mm
height 5000 mm
depth 3375 mm
 1270 mm filtration



General view of the machine.

- Minimum dimensions foam buns
 - width 800 mm
 - height 1550 mm
 - depth 835 mm
- Maximum dimensions foam buns
 - width 1820 mm
 - height 3000 mm
 - depth 1750 mm
- Bandsaw has a vertical axis of the wheel.
- The saw band has a speed of 17.5 m / s at 50Hz. Motor output of 2.2 kW.
- Speed is adjustable.
- The saw moves vertically from above – downwards.
- The saw has a lifting speed of 10 m / min at 50Hz. Motor output of 3.0 kW.
- Speed is adjustable.
- Rear, movable wall for depth adjustment.
- The maximum depth of the notch 200 mm.
- Adjustable range of 835 - 1750 mm from the blade saw.
- The foam buns is clamped to the back wall. The actuator is pneumatic. Control is manual.
- Lifting and rotating table. Manually rotating the foam bun in the machine.
- Founding foam buns into the machine - elevating technique. It is believed the manual handling of foam bun inside the machine.
- High-speed door Hörmann, type V 5015 SEL, width 2.5 m, height 3.5 m, with control box BK150FUEH.

- Covering - the entire machine is covered with polycarbonate panels.
- Line laser for marking the position of the cut, the type of 24V AC / DC - 5mW.
- Automatic or manual machine mode.
- Vacuum hose connected to the saw's dust collection port.
- Electrical installations
 - Supply voltage 400V,
 - Power system TN-S 3F + PE protective and occupational N
 - Maximum current 32A
 - Nominal frequency 50 Hz
 - Performance 14kW
 - Supply voltage control circuit 230V/24V DC, system control circuits PELV
 - Supply voltage control inputs 24V DC
 - Control system Schneider M238
- Tires installation
 - Unadjusted air 25 μ m
 - P max. 6 bar
 - Pneumatic components Festo
- Filtration
 - Type filtration bag filter PFV 2/2-630/2000
 - Total suction power 4 - 5000 m³/h
 - The volume of bags 4 x 300 l
 - Pipeline VZT circular galvanized sk: I, SPIRO
 - The level sensor (full) NIVELCO RLH-302-E



Loading foam buns into the machine.



Control panel and switchboard.



**Control panel
rear wall of the forward / backward, clamp / unclamp
buns and lifting / tilting rotary table.**

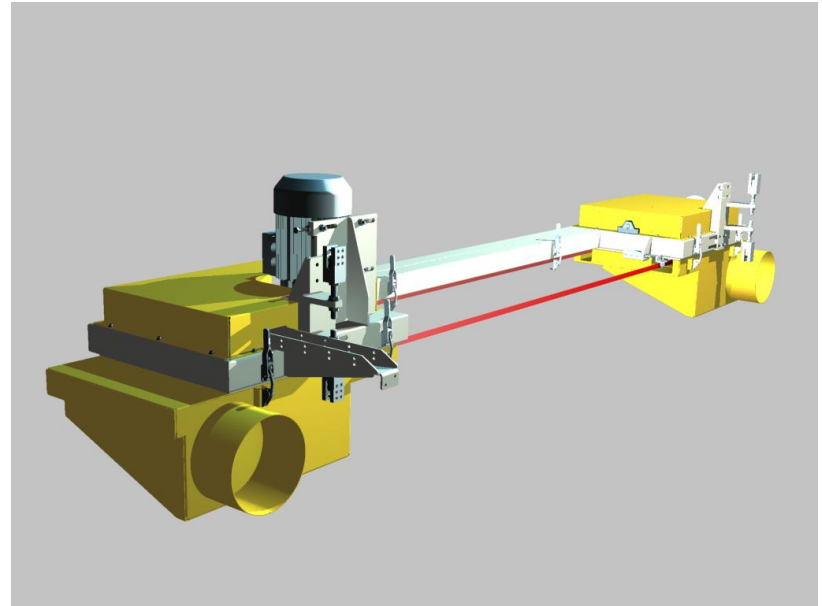
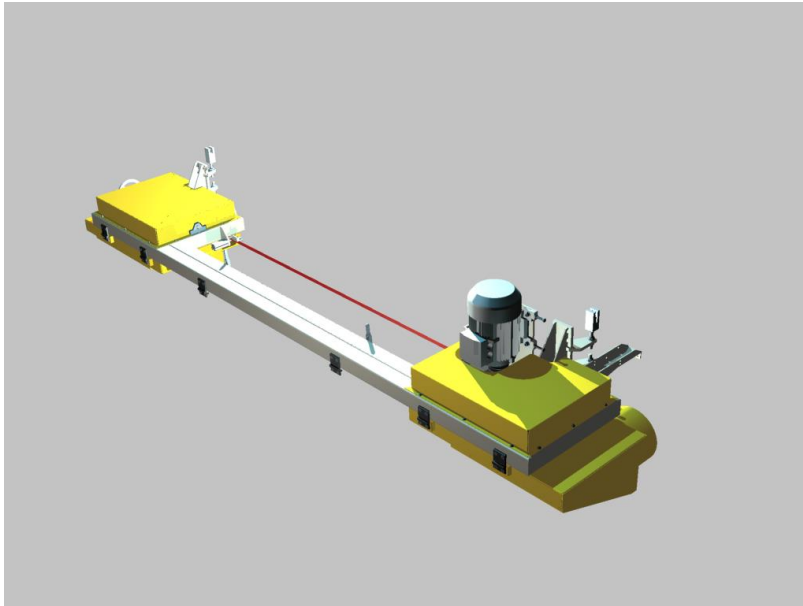

The saw - front / rear view.



The saw in the working cycle.

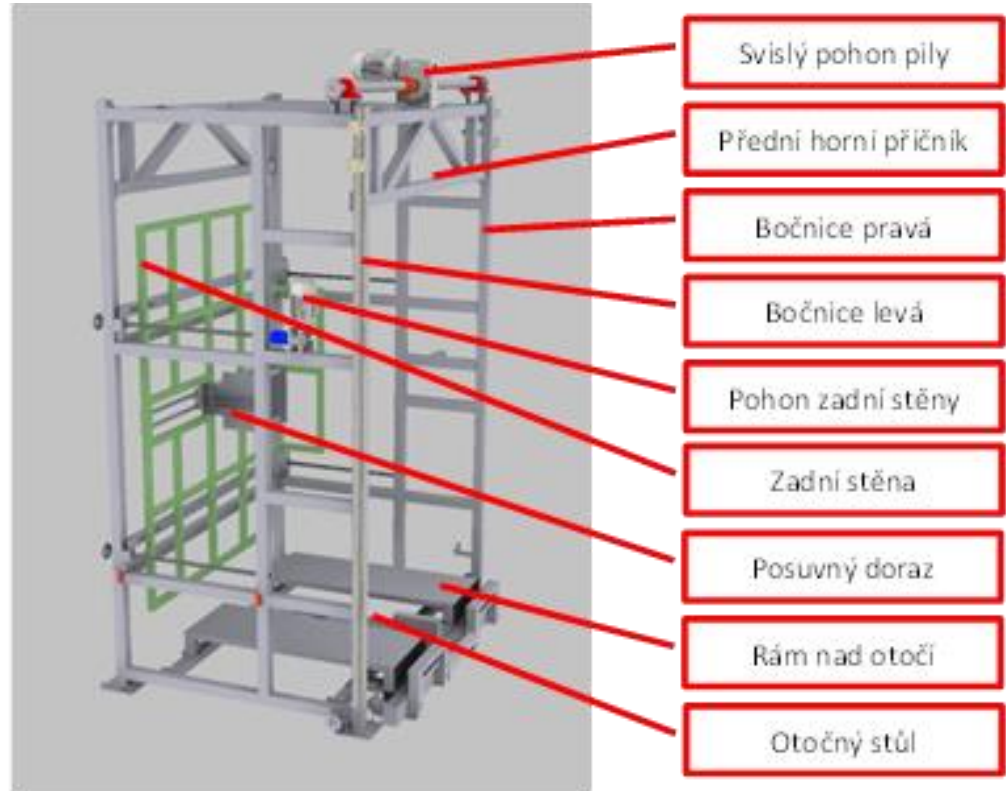

The internal arrangement trimming machine.

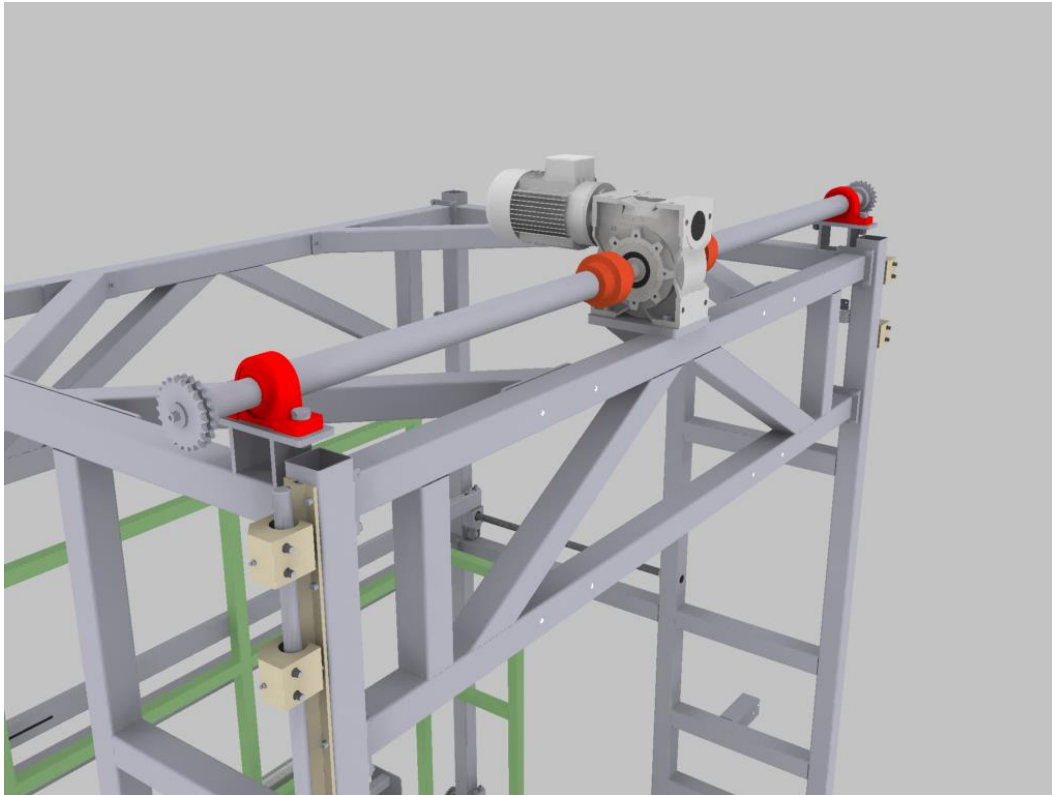

The saw moves vertically.



Rear wall for clamping buns.



Measuring the distance from the wall and blade saw.



Drive wall.



Clamping buns.



Chain tensioning.



Drive wall.



Lifting and rotating table.



Line laser for marking the position of the cut.



Bag filter PFV 2/2-630/2000 and pipe.



Safety signs.

BETKI s.r.o.
U Studia 33
700 30 Ostrava – Zábřeh
Czech Republic

e-mail: betki@betki.eu
www.betki.eu

Identif. number: 29385245
Tax identity: CZ29385245

IBAN: CZ4501000001070392010207
SWIFT (BIC) KOMBCZPPXXX